



*A more robust  
and reliable  
filter assembly*

# F7F Series Duplex Filter Assemblies

Low Pressure Hydraulic Filter Assemblies

## Features

- 350 psi (24 bar) operating pressure
- 40, 80 & 100 gpm (151, 303 & 379 lpm) nominal flow rates
- SAE -24 straight thread or SAE 4-bolt flange ports
- Elements available with  $\beta_{x(c)} \geq 1000$  Glas-Tech® media
- Optional visual & electrical indicators
- Self locking transfer valve
- Automatic bleed-over valve

## Technical Data

### Pressure & Temperature Rating

Operating Pressure:	350 psi (24 bar)
Proof Pressure:	700 psi (48 bar)
Burst Pressure:	1,050 psi (72 bar)
Operating Temperature:	-40°F to +250°F (-40°C to +121°C)

### Materials of Construction

Head:	Anodized Aluminum Alloy
Bowl - 040 & 080:	Anodized Aluminum Alloy
Bowl - 100:	Steel

### Bypass Options

Bypass Valve Setting:	50 psid (3.4 bar) ±10%
-----------------------	------------------------

### Differential Pressure Indicators

Visual Indicator :	32 psid (2.2 bar) ±10% activation, manual reset
	32 psid (2.2 bar) ±10% activation, self resetting
Visual & Electrical Indicator:	32 psid (2.2 bar) ±10% activation 12 to 220 Volt AC/DC, 2.5 AMP, 60VA, 40W Contacts - SPST NO or NC, DIN Connector
Thermal Lockout Options:	Lockout below 70°F (21°C) Release above 95°F (35°C)

### Seal Material Options

Seal Material:	Buna Viton®
----------------	----------------

### Filter Assembly (Housing & Element) Weight

Size	040	080	100
Weight	20 lbs (9.1 kg)	23 lbs (10.4 kg)	44 lbs (20 kg)



## Elements

PTI filter elements are manufactured with the highest quality materials. PTI filter elements feature multi-layer construction for increased dirt-holding capacity and low pressure drop. PTI elements provide cost-effective contamination control for the most demanding applications. All elements are tested to the latest industry standards including ISO 16889 procedure for multipass efficiency testing.

<b>Filtration Rating</b>			
Multipass Test results per old ISO 4572 and new ISO 16889 test procedures			
Particle size (x) in microns at which the Beta Ratio ( $\beta$ ) is greater than or equal to the indicated value (200 or 1000).			
	Per ISO 4572	Per ISO 16889	
Code	$\beta_x \geq 200$	$\beta_{x(c)} \geq 200$	$\beta_{x(c)} \geq 1000$
V	1 $\mu$ m	4.2 $\mu$ m	4.2 $\mu$ m
G	3 $\mu$ m	5 $\mu$ m	7 $\mu$ m
H	6 $\mu$ m	7 $\mu$ m	9 $\mu$ m
K	12 $\mu$ m	12 $\mu$ m	15 $\mu$ m
J	23 $\mu$ m	21 $\mu$ m	24 $\mu$ m

The PTI Technologies F7F series of low pressure hydraulic filter assemblies utilize PG Series filter elements. Please refer to the PG Series Filter Element brochure for flow vs. pressure drop curves.

## Flow Rate/Pressure Drop Curves

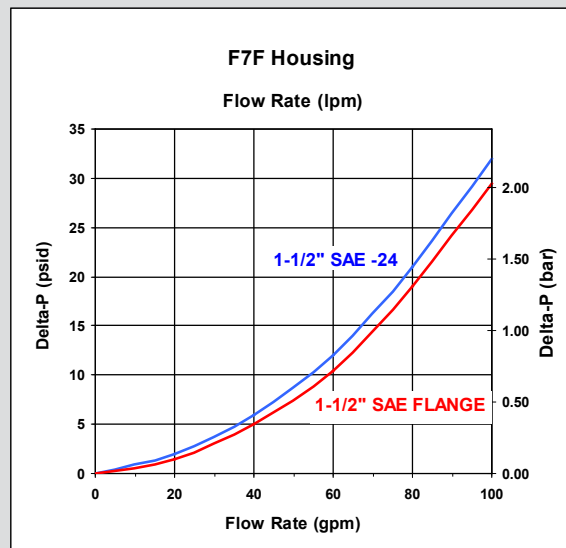

Pressure drop curves are based on 150 SUS (32 cSt) petroleum base hydraulic fluid of 0.9 S.G.  
 Filter Assembly  $\Delta P$  = Housing  $\Delta P$  + Element  $\Delta P$

# Dimensions\*

\* Dimensions in inches (mm)

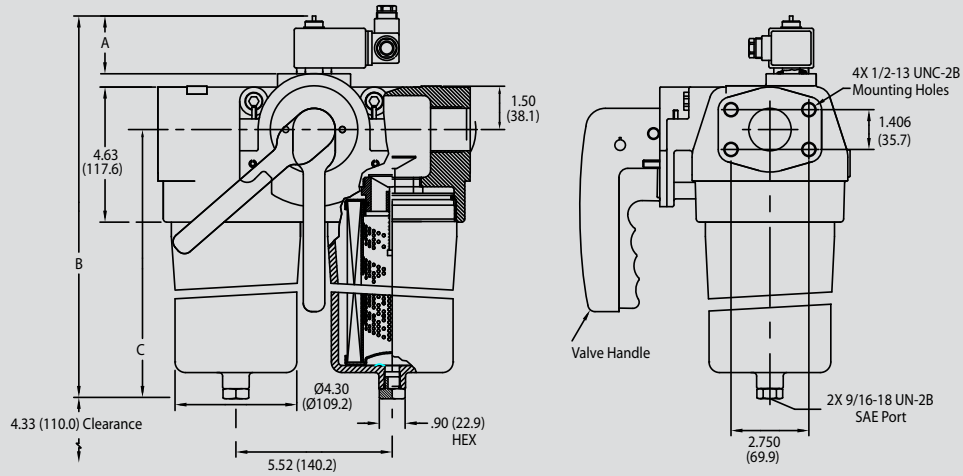

Dimensions

Nominal Flow	-040	-080	-081	-100	-121
Dimension A	2.56 (65.0)	1.95 (49.5)	1.95 (49.5)	1.95 (49.5)	1.95 (49.5)
Dimension B	12.80 (325.1)	17.40 (442.0)	17.40 (442.0)	21.97 (558.0)	21.97 (558.0)
Dimension C	8.80 (223.5)	13.40 (340.4)	13.40 (340.4) *	17.96 (456.2)	17.96 (456.2) **

\*HF3-030 Elements

\*\*HF3-050 Elements

## Ordering Information

### Assembly:

F7F	XXX	X	X	-	X	X	X	X	X
TBL 1	TBL 2	TBL 3	TBL 4	TBL 5	TBL 6	TBL 7	TBL 8	TBL 9	

Code	Nominal Flow
040	40 gpm (151 lpm)
080	80 gpm (303 lpm)
100	100 gpm (379 lpm)

Code	Micron Rating	Media
V	$\beta_{4.2(c)} \geq 1000$	Glas-Tech
G	$\beta_{7(c)} \geq 1000$	Glas-Tech
H	$\beta_{9(c)} \geq 1000$	Glas-Tech
K	$\beta_{15(c)} \geq 1000$	Glas-Tech
J	$\beta_{24(c)} \geq 1000$	Glas-Tech
N	No Filter Element	

Code	Collapse Rating
H	300 psid (21 bar)
U	3,000 psid (207 bar)
N	No Filter Element

Code	Material
B	Buna
V	Viton®

Viton® is a registered trademark of DuPont Performance Elastomers

Code	Option
P	1-1/2" SAE (-24)
4	1-1/2" SAE Flange Code 61*

\* SAE J518

Code	Option
O	None
T*	Thermal Lockout - NO
U*	Normally Closed - NC

\* Options only available for K code Indicator (See Table 7)

Code	Option
B	Visual 32 psid (2.2 bar) ±10% Manual Reset
K	Visual/Electrical 32 psid (2.2 bar) ±10%
P	None (Blind Plug)
Q	Visual 32 psid (2.2 bar) ±10% Self Resetting

Code	Option
H	50 psid (3.4 bar) ±10%
N	None

Code	Option
X	Vent & Drain Ports

### Element:

PG	-	XXX	-	X	X	-	X
TBL 1	TBL 2	TBL 3	TBL 4				

Code	Nominal Flow
050*	50 gpm (189 lpm)
080	80 gpm (303 lpm)
120**	120 gpm (454 lpm)

\* Use PG-050 Element For F7F -040 Series

Series

\*\*Use PG-120 Element For F7F -100 Series

Series

Code	Micron Rating	Media
V	$\beta_{4.2(c)} \geq 1000$	Glas-Tech
G	$\beta_{7(c)} \geq 1000$	Glas-Tech
H	$\beta_{9(c)} \geq 1000$	Glas-Tech
K	$\beta_{15(c)} \geq 1000$	Glas-Tech
J	$\beta_{24(c)} \geq 1000$	Glas-Tech

Code	Collapse Rating
H	300 psid (21 bar)
U	3,000 psid (207 bar)

Code	Option
Omit	Standard Element
W	DryPak™ Configuration